



CY74FCT16240T CY74FCT162240T

16-Bit Buffers/Line Drivers

Features

- Low power, pin compatible replacement for ABT functions
- FCT-E speed at 3.2 ns
- Power-off disable outputs permits live insertion
- Edge-rate control circuitry for significantly improved noise characteristics
- Typical output skew < 250 ps
- ESD > 2000V
- TSSOP (19.6-mil pitch) and SSOP (25-mil pitch) packages
- Industrial temperature range of -40°C to +85°C
- V_{CC} = 5V ± 10%

CY74FCT16240T Features:

- 64 mA sink current, 32 mA source current
- Typical V_{OLP} (ground bounce) < 1.0V at V_{CC} = 5V, T_A = 25°C

CY74FCT162240T Features:

- Balanced output drivers: 24 mA
- Reduced system switching noise
- Typical V_{OLP} (ground bounce) < 0.6V at V_{CC} = 5V, T_A = 25°C

Functional Description

These 16-bit buffer/line drivers are used in memory driver, clock driver, or other bus interface applications, where high speed and low power are required. With flow-through pinout and small shrink packaging, board layout is simplified. The three-state controls are designed to allow 4-, 8-, or 16-bit operation. The outputs are designed with a power-off disable feature to allow for live insertion of boards.

The CY74FCT16240T is ideally suited for driving high-capacitance loads and low-impedance backplanes.

The CY74FCT162240T has 24-mA balanced output drivers with current limiting resistors in the outputs. This reduces the need for external terminating resistors and provides for minimal undershoot and reduced ground bounce. The CY74FCT162240T is ideal for driving transmission lines.

Logic Block Diagrams

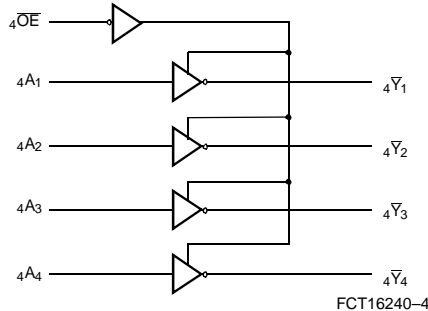
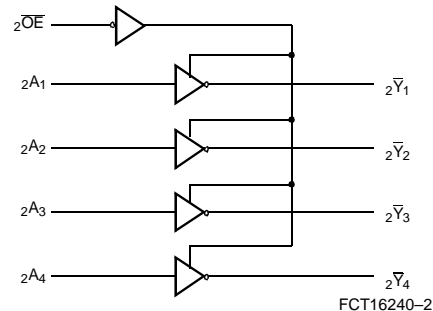
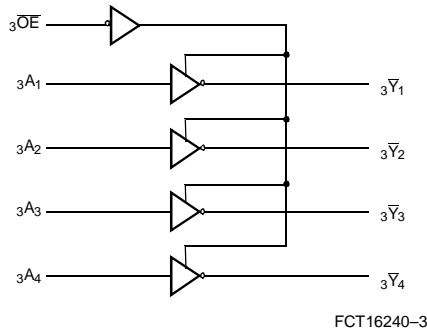
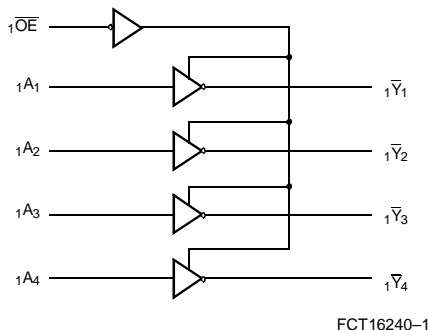

Pin Configuration

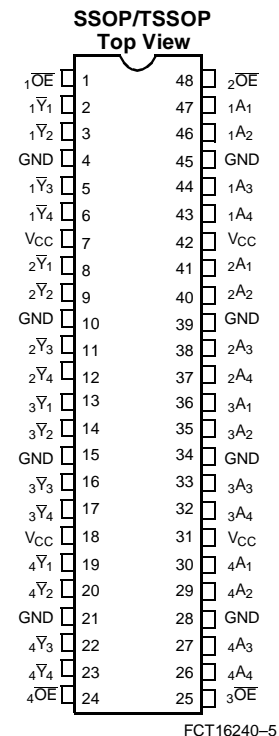



Pin Summary

Name	Description
\overline{OE}	Three-State Output Enable Inputs (Active LOW)
A	Data Inputs
\overline{Y}	Three-State Outputs

Function Table^[1]

Inputs		Outputs
\overline{OE}	A	\overline{Y}
L	L	H
L	H	L
H	X	Z

Maximum Ratings^[2, 3]

(Above which the useful life may be impaired. For user guidelines, not tested.)

Storage Temperature Com'l. -55°C to +125°C

Ambient Temperature with Power Applied..... Com'l. -55°C to +125°C

DC Input Voltage -0.5V to +7.0V

DC Output Voltage..... -0.5V to +7.0V

DC Output Current (Maximum Sink Current/Pin) -60 to +120 mA

Power Dissipation 1.0W

Static Discharge Voltage (per MIL-STD-883, Method 3015) >2001V

Operating Range

Range	Ambient Temperature	V _{CC}
Industrial	-40°C to +85°C	5V ± 10%

Electrical Characteristics Over the Operating Range

Parameter	Description	Test Conditions	Min.	Typ. ^[4]	Max.	Unit
V _{IH}	Input HIGH Voltage		2.0			V
V _{IL}	Input LOW Voltage				0.8	V
V _H	Input Hysteresis ^[5]			100		mV
V _{IK}	Input Clamp Diode Voltage	V _{CC} = Min., I _{IN} = -18 mA		-0.7	-1.2	V
I _{IH}	Input HIGH Current	V _{CC} = Max., V _I = V _{CC}			±1	µA
I _{IH}	Input HIGH Current	V _{CC} = Max., V _I = V _{CC}			±1	µA
I _{IL}	Input LOW Current	V _{CC} = Max., V _I = GND			±1	µA
I _{IL}	Input LOW Current	V _{CC} = Max., V _I = GND			±1	µA
I _{OZH}	High Impedance Output Current (Three-State Output pins)	V _{CC} = Max., V _{OUT} = 2.7V			±1	µA
I _{OZL}	High Impedance Output Current (Three-State Output pins)	V _{CC} = Max., V _{OUT} = 0.5V			±1	µA
I _{OS}	Short Circuit Current ^[6]	V _{CC} = Max., V _{OUT} = GND	-80	-140	-200	mA
I _O	Output Drive Current ^[6]	V _{CC} = Max., V _{OUT} = 2.5V	-50		-180	mA
I _{OFF}	Power-Off Disable	V _{CC} = 0V, V _{OUT} ≤ 4.5V ^[7]			±1	µA

Output Drive Characteristics for CY74FCT16240T

Parameter	Description	Test Conditions	Min.	Typ. ^[4]	Max.	Unit
V _{OH}	Output HIGH Voltage	V _{CC} = Min., I _{OH} = -3 mA	2.5	3.5		V
		V _{CC} = Min., I _{OH} = -15 mA	2.4	3.5		V
		V _{CC} = Min., I _{OH} = -32 mA	2.0	3.0		V
V _{OL}	Output LOW Voltage	V _{CC} = Min., I _{OL} = 64 mA		0.2	0.55	V

Note:

- H = HIGH Voltage Level. L = LOW Voltage Level. X = Don't Care. Z = High Impedance.
- Operation beyond the limits set forth may impair the useful life of the device. Unless noted, these limits are over the operating free-air temperature range.
- Unused inputs must always be connected to an appropriate logic voltage level, preferably either V_{CC} or ground.
- Typical values are at V_{CC}=5.0V, T_A= +25°C ambient.
- This parameter is guaranteed but not tested.
- Not more than one output should be shorted at a time. Duration of short should not exceed one second. The use of high-speed test apparatus and/or sample and hold techniques are preferable in order to minimize internal chip heating and more accurately reflect operational values. Otherwise prolonged shorting of a high output may raise the chip temperature well above normal and thereby cause invalid readings in other parametric tests. In any sequence of parameter tests, I_{OS} tests should be performed last.
- Tested at +25°C.

Output Drive Characteristics for CY74FCT162240T

Parameter	Description	Test Conditions	Min.	Typ. ^[4]	Max.	Unit
I _{ODL}	Output LOW Current ^[6]	V _{CC} = 5V, V _{IN} = V _{IH} or V _{IL} , V _{OUT} = 1.5V	60	115	150	mA
I _{ODH}	Output HIGH Current ^[6]	V _{CC} = 5V, V _{IN} = V _{IH} or V _{IL} , V _{OUT} = 1.5V	-60	-115	-150	mA
V _{OH}	Output HIGH Voltage	V _{CC} = Min., I _{OH} = -24 mA	2.4	3.3		V
V _{OL}	Output LOW Voltage	V _{CC} = Min., I _{OL} = 24 mA		0.3	0.55	V

Capacitance^[5] (T_A = +25°C, f = 1.0 MHz)

Parameter	Description	Test Conditions	Typ. ^[4]	Max.	Unit
C _{IN}	Input Capacitance	V _{IN} = 0V	4.5	6.0	pF
C _{OUT}	Output Capacitance	V _{OUT} = 0V	5.5	8.0	pF

Power Supply Characteristics

Parameter	Description	Test Conditions	Typ. ^[1]	Max.	Unit	
I _{CC}	Quiescent Power Supply Current	V _{CC} =Max. V _{IN} ≤0.2V, V _{IN} ≥V _{CC} -0.2V	5	500	μA	
ΔI _{CC}	Quiescent Power Supply Current (TTL inputs HIGH)	V _{CC} =Max. V _{IN} =3.4V ^[8]	0.5	1.5	mA	
I _{CCD}	Dynamic Power Supply Current ^[9]	V _{CC} =Max., One Input Toggling, 50% Duty Cycle, Outputs Open, \overline{OE} =GND	60	100	μA/MHz	
I _C	Total Power Supply Current ^[10]	V _{CC} =Max., f ₁ =10 MHz, 50% Duty Cycle, Outputs Open, One Bit Toggling, \overline{OE} =GND	V _{IN} =V _{CC} or V _{IN} =GND	0.6	1.5	mA
			V _{IN} =3.4V or V _{IN} =GND	0.9	2.3	mA
		V _{CC} =Max., f ₁ =2.5 MHz, 50% Duty Cycle, Outputs Open, Sixteen Bits Toggling, \overline{OE} =GND	V _{IN} =V _{CC} or V _{IN} =GND	2.4	4.5 ^[11]	mA
			V _{IN} =3.4V or V _{IN} =GND	6.4	16.5 ^[11]	mA

Notes:

8. Per TTL driven input (V_{IN}=3.4V); all other inputs at V_{CC} or GND.
9. This parameter is not directly testable, but is derived for use in Total Power Supply calculations.
10. I_C = I_{QUIESCENT} + I_{INPUTS} + I_{DYNAMIC}
I_C = I_{CC} + ΔI_{CC}D_HN_T + I_{CCD}(f₀/2 + f₁N₁)
I_{CC} = Quiescent Current with CMOS input levels
ΔI_{CC} = Power Supply Current for a TTL HIGH input (V_{IN}=3.4V)
D_H = Duty Cycle for TTL inputs HIGH
N_T = Number of TTL inputs at D_H
I_{CCD} = Dynamic Current caused by an input transition pair (HLH or LHL)
f₀ = Clock frequency for registered devices, otherwise zero
f₁ = Input signal frequency
N₁ = Number of inputs changing at f₁
All currents are in milliamps and all frequencies are in megahertz.
11. Values for these conditions are examples of the I_{CC} formula. These limits are guaranteed but not tested.



Switching Characteristics Over the Operating Range^[12]

Parameter	Description	CY74FCT16240T CY74FCT162240T		CY74FCT16240AT CY74FCT162240AT		Unit	Fig. No. ^[13]
		Min.	Max.	Min.	Max.		
t _{PLH} t _{PHL}	Propagation Delay Data to Output	1.5	8.0	1.5	4.8	ns	1, 2
t _{PZH} t _{PZL}	Output Enable Time	1.5	10.0	1.5	6.2	ns	1, 7, 8
t _{PHZ} t _{PLZ}	Output Disable Time	1.5	9.5	1.5	5.6	ns	1, 7, 8
t _{SK(O)}	Output Skew ^[14]		0.5		0.5	ns	—

Parameter	Description	CY74FCT16240CT CY74FCT162240CT		CY74FCT16240ET CY74FCT162240ET		Unit	Fig. No. ^[13]
		Min.	Max.	Min.	Max.		
t _{PLH} t _{PHL}	Propagation Delay Data to Output	1.5	4.3	1.5	3.2	ns	1, 2
t _{PZH} t _{PZL}	Output Enable Time	1.5	5.8	1.5	4.4	ns	1, 7, 8
t _{PHZ} t _{PLZ}	Output Disable Time	1.5	5.2	1.5	3.6	ns	1, 7, 8
t _{SK(O)}	Output Skew ^[14]		0.5		0.5	ns	—

Note:

- 12. Minimum limits are guaranteed but not tested on Propagation Delays.
- 13. See "Parameter Measurement Information" in the General Information section.
- 14. Skew between any two outputs of the same package switching in the same direction. This parameter is guaranteed by design.

Ordering Information CY74FCT16240

Speed (ns)	Ordering Code	Package Name	Package Type	Operating Range
3.2	CY74FCT16240ETPAC	Z48	48-Lead (240-Mil) TSSOP	Industrial
	CY74FCT16240ETPVC	O48	48-Lead (300-Mil) SSOP	
4.3	CY74FCT16240CTPAC	Z48	48-Lead (240-Mil) TSSOP	Industrial
	CY74FCT16240CTPVC	O48	48-Lead (300-Mil) SSOP	
4.8	CY74FCT16240ATPAC	Z48	48-Lead (240-Mil) TSSOP	Industrial
	CY74FCT16240ATPVC	O48	48-Lead (300-Mil) SSOP	
8.0	CY74FCT16240TPAC	Z48	48-Lead (240-Mil) TSSOP	Industrial
	CY74FCT16240TPVC	O48	48-Lead (300-Mil) SSOP	

Ordering Information CY74FCT162240

Speed (ns)	Ordering Code	Package Name	Package Type	Operating Range
3.2	CY74FCT162240ETPAC	Z48	48-Lead (240-Mil) TSSOP	Industrial
	CY74FCT162240ETPVC	O48	48-Lead (300-Mil) SSOP	
4.3	CY74FCT162240CTPAC	Z48	48-Lead (240-Mil) TSSOP	Industrial
	CY74FCT162240CTPVC	O48	48-Lead (300-Mil) SSOP	
4.8	CY74FCT162240ATPAC	Z48	48-Lead (240-Mil) TSSOP	Industrial
	CY74FCT162240ATPVC	O48	48-Lead (300-Mil) SSOP	
8.0	CY74FCT162240TPAC	Z48	48-Lead (240-Mil) TSSOP	Industrial
	CY74FCT162240TPVC	O48	48-Lead (300-Mil) SSOP	

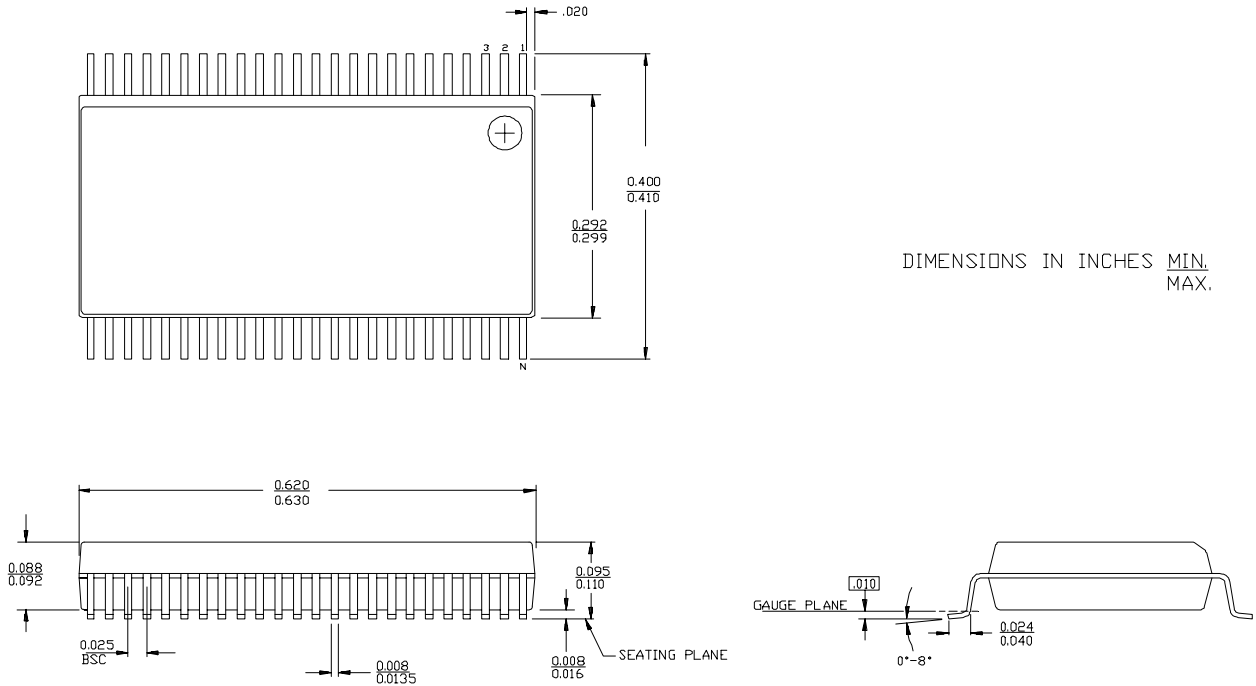
Package Diagrams
48-Lead Shrunk Small Outline Package O48

48-Lead Thin Shrunk Small Outline Package
