

**FEATURES**

- Translates positive ECL to TTL (PECL-to-TTL)
- 300ps pin-to-pin skew
- 500ps part-to-part skew
- Differential internal design for increased noise immunity and stable threshold inputs
- VBB reference output
- Single supply
- Enable input
- Extra TTL and ECL power/ground pins to reduce cross-talk/noise
- High drive capability: 24mA each output
- ESD protection of 2000V
- Fully compatible with industry standard 10K, 100K I/O levels

**DESCRIPTION**

The SY10/100H842 are single supply, low skew translating 1:4 clock drivers.

The devices feature a 24mA TTL output stage, with AC performance specified into a 50pF load capacitance. A HIGH on the enable pin (EN) forces all outputs LOW.

As frequencies increase to 40MHz and above, precise timing and shaping of clock signals becomes extremely important. The H842 solves several clock distribution problems such as minimizing skew (300ps), maximizing clock fanout (24mA drive), and precise duty cycle control through a proprietary differential internal design.

The 10K version is compatible with 10KH ECL logic levels. The 100K version is compatible with 100K levels.

**PIN CONFIGURATION**

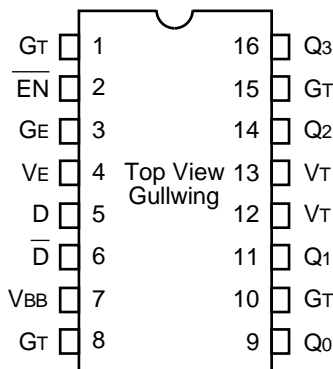

**BLOCK DIAGRAM**

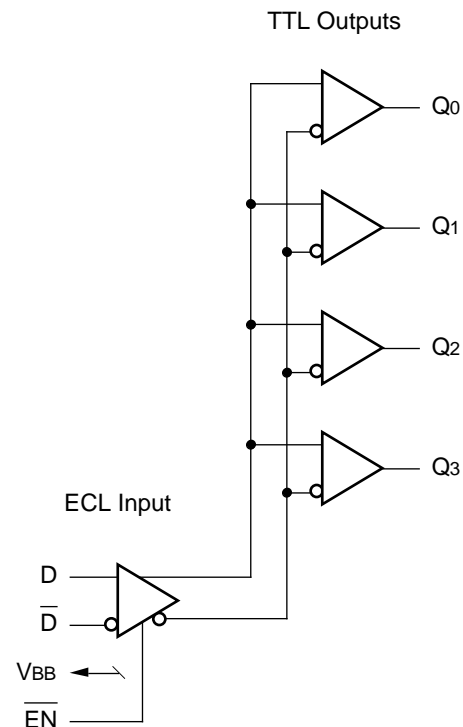

**PIN NAMES**

Pin	Function
GT	TTL Ground (0V)
VT	TTL Vcc (+5.0V)
VE	ECL Vcc (+5.0V)
GE	ECL Ground (0V)
D, D̄	Signal Input (PECL)
VBB	VBB Reference Output (PECL)
Q0 - Q3	Signal Outputs (TTL)
EN	Enable Input (PECL)

## ABSOLUTE MAXIMUM RATINGS<sup>(1)</sup>

Rating	Symbol	Value	Unit
Power Supply Voltage	V <sub>E</sub> (ECL)	-0.5 to +7.0	V
	V <sub>T</sub> (TTL)	-0.5 to +7.0	
Input Voltage	V <sub>I</sub> (ECL)	0.0 to V <sub>EE</sub>	V
	V <sub>OUT</sub> (TTL)	0.0 to V <sub>T</sub>	
Storage Temperature	T <sub>store</sub>	-65 to +150	°C
Operating Temperature	T <sub>amb</sub>	0.0 to +85	°C

NOTE:

1. Permanent device damage may occur if ABSOLUTE MAXIMUM RATINGS are exceeded. This is a stress rating only and functional operation is not implied at conditions other than those detailed in the operational sections of this data sheet. Exposure to ABSOLUTE MAXIMUM RATING conditions for extended periods may affect device reliability.

## TRUTH TABLE

D	$\overline{\text{EN}}$	Q
L	L	L
H	L	H
X	H	L

## PIN DESCRIPTION

Pin	Symbol	Description
1	GT	TTL Ground (0V)
2	$\overline{\text{EN}}$	Enable Input (PECL)
3	GE	ECL Ground (0V)
4	V <sub>E</sub>	ECL V <sub>cc</sub> (+5.0V)
5	D	ECL Signal Input (Non-inverting)
6	$\overline{\text{D}}$	ECL Signal Input (Inverting)
7	V <sub>BB</sub>	V <sub>BB</sub> Reference Output (PECL)
8	GT	TTL Ground (0V)
9	Q <sub>0</sub>	Signal Output (TTL)
10	GT	TTL Ground (0V)
11	Q <sub>1</sub>	Signal Output (TTL)
12	V <sub>T</sub>	TTL V <sub>cc</sub> (+5.0V)
13	V <sub>T</sub>	TTL V <sub>cc</sub> (+5.0V)
14	Q <sub>2</sub>	Signal Output (TTL)
15	GT	TTL Ground (0V)
16	Q <sub>3</sub>	Signal Output (TTL)

## DC CHARACTERISTICS

$V_T = V_E = 5.0V \pm 5\%$

Symbol	Parameter		T <sub>A</sub> = 0°C		T <sub>A</sub> = +25°C		T <sub>A</sub> = +85°C		Unit	Condition
			Min.	Max.	Min.	Max.	Min.	Max.		
IEE	Power Supply Current	ECL	—	35	—	35	—	35	mA	V <sub>E</sub> Pin
ICCH	Power Supply Current	TTL	—	20	—	20	—	20	mA	Total all V <sub>T</sub> pins
ICCL			—	25	—	25	—	25		

## AC CHARACTERISTICS

$V_T = V_E = 5.0V \pm 5\%$

Symbol	Parameter		T <sub>A</sub> = 0°C		T <sub>A</sub> = +25°C		T <sub>A</sub> = +85°C		Unit	Condition
			Min.	Max.	Min.	Max.	Min.	Max.		
t <sub>PLH</sub> t <sub>PHL</sub>	Propagation Delay D to Output	Q <sub>0</sub> –Q <sub>3</sub>	2.5	3.5	2.5	3.5	2.5	3.5	ns	CL = 50pF
tskpp	Part-to-Part Skew <sup>(1,4)</sup>	Q <sub>0</sub> –Q <sub>3</sub>	—	0.5	—	0.5	—	0.5	ns	CL = 50pF
tskew++	Within-Device Skew <sup>(2,4)</sup>	Q <sub>0</sub> –Q <sub>3</sub>	—	0.3	—	0.3	—	0.3	ns	CL = 50pF
tskew--	Within-Device Skew <sup>(3,4)</sup>	Q <sub>0</sub> –Q <sub>3</sub>	—	0.3	—	0.3	—	0.3	ns	CL = 50pF
t <sub>PLH</sub> t <sub>PHL</sub>	Propagation Delay $\overline{EN}$ to Output	Q <sub>0</sub> –Q <sub>3</sub>	2.5	3.5	2.5	3.5	2.5	3.5	ns	CL = 50pF
t <sub>r</sub> t <sub>f</sub>	Output Rise/Fall Time 1.0V to 2.0V	Q <sub>0</sub> –Q <sub>3</sub>	—	1.5	—	1.5	—	1.5	ns	CL = 50pF
f <sub>MAX</sub>	Max. Input Frequency <sup>(5,6)</sup>	Q <sub>0</sub> –Q <sub>3</sub>	160	—	160	—	160	—	MHz	CL = 50pF

### NOTES:

1. Device-to-Device Skew considering HIGH-to-HIGH transitions at common V<sub>CC</sub> level.
2. Within-Device Skew considering HIGH-to-HIGH transitions at common V<sub>CC</sub> level.
3. Within-Device Skew considering LOW-to-LOW transitions at common V<sub>CC</sub> level.
4. All skew parameters are guaranteed but not tested.
5. Frequency at which output levels will meet a 0.8V to 2.0V minimum swing.
6. The f<sub>MAX</sub> value is specified as the minimum guaranteed maximum frequency. Actual operational maximum frequency may be greater.

## VCC AND CLOAD

Ranges to meet duty cycle requirement: 0°C ≤ T<sub>A</sub> ≤ 85°C. Output duty cycle measured relative to 1.5V.

Symbol	Parameter		Min.	Typ.	Max.	Unit	Condition
Pw	Ranges of V <sub>CC</sub> and C <sub>L</sub> to meet min. pulse width (HIGH or LOW) at f <sub>OUT</sub> ≤ 40MHz	V <sub>CC</sub>	4.75	5.0	5.25	V	All Outputs
		C <sub>L</sub>	10	—	50	pF	
		Pw	11	—	—	ns	
Pw	Ranges of V <sub>CC</sub> and C <sub>L</sub> to meet min. pulse width (HIGH or LOW) at f <sub>OUT</sub> ≤ 50MHz	V <sub>CC</sub>	4.875	5.0	5.125	V	All Outputs
		C <sub>L</sub>	15	—	27	pF	
		Pw	9.0	—	—	ns	

### TTL DC ELECTRICAL CHARACTERISTICS

$V_T = V_E = +5.0V \pm 5\%$

Symbol	Parameter	T <sub>A</sub> = 0°C		T <sub>A</sub> = +25°C		T <sub>A</sub> = +85°C		Unit	Condition
		Min.	Max.	Min.	Max.	Min.	Max.		
V <sub>OH</sub>	Output HIGH Voltage	2.5 2.0	— —	2.5 2.0	— —	2.5 2.0	— —	V	I <sub>OH</sub> = -3.0mA I <sub>OH</sub> = -15mA
V <sub>OL</sub>	Output LOW Voltage	—	0.5	—	0.5	—	0.5	V	I <sub>OL</sub> = 24mA
I <sub>OS</sub>	Output Short Circuit Current	-80	-200	-80	-200	-80	-200	mA	V <sub>OUT</sub> = 0V

### 10H ECL DC ELECTRICAL CHARACTERISTICS<sup>(1)</sup>

$V_T = V_E = +5.0V \pm 5\%$

Symbol	Parameter	T <sub>A</sub> = 0°C		T <sub>A</sub> = +25°C		T <sub>A</sub> = +85°C		Unit	Condition
		Min.	Max.	Min.	Max.	Min.	Max.		
I <sub>IH</sub>	Input HIGH Current	—	225	—	175	—	175	μA	—
I <sub>IL</sub>	Input LOW Current	0.5	—	0.5	—	0.5	—	μA	—
V <sub>IH</sub>	Input HIGH Voltage	3.830	4.160	3.870	4.190	3.940	4.280	V	V <sub>E</sub> = 5.0V
V <sub>IL</sub>	Input LOW Voltage	3.050	3.520	3.050	3.520	3.050	3.555	V	V <sub>E</sub> = 5.0V
V <sub>BB</sub>	Output Reference Voltage	3.620	3.730	3.650	3.750	3.690	3.810	V	V <sub>E</sub> = 5.0V

NOTE:

1. ECL V<sub>IH</sub>, V<sub>IL</sub> and V<sub>BB</sub> are referenced to V<sub>CC</sub>E and will vary 1:1 with the power supply. The levels shown are for I<sub>VT</sub> = I<sub>VO</sub> = V<sub>CC</sub>E = +5.0V.

### 100H ECL DC ELECTRICAL CHARACTERISTICS<sup>(1)</sup>

$V_T = V_E = +5.0V \pm 5\%$

Symbol	Parameter	T <sub>A</sub> = 0°C		T <sub>A</sub> = +25°C		T <sub>A</sub> = +85°C		Unit	Condition
		Min.	Max.	Min.	Max.	Min.	Max.		
I <sub>IH</sub>	Input HIGH Current	—	225	—	175	—	175	μA	—
I <sub>IL</sub>	Input LOW Current	0.5	—	0.5	—	0.5	—	μA	—
V <sub>IH</sub>	Input HIGH Voltage	3.835	4.120	3.835	4.12	3.835	4.120	V	V <sub>E</sub> = 5.0V
V <sub>IL</sub>	Input LOW Voltage	3.190	3.525	3.1900	3.525	3.190	3.525	V	V <sub>E</sub> = 5.0V
V <sub>BB</sub>	Output Reference Voltage	3.620	3.740	3.62	3.740	3.620	3.740	V	V <sub>E</sub> = 5.0

NOTE:

1. ECL V<sub>IH</sub>, V<sub>IL</sub> and V<sub>BB</sub> are referenced to V<sub>CC</sub>E and will vary 1:1 with the power supply. The levels shown are for I<sub>VT</sub> = I<sub>VO</sub> = V<sub>CC</sub>E = +5.0V.

## TTL SWITCHING CIRCUIT

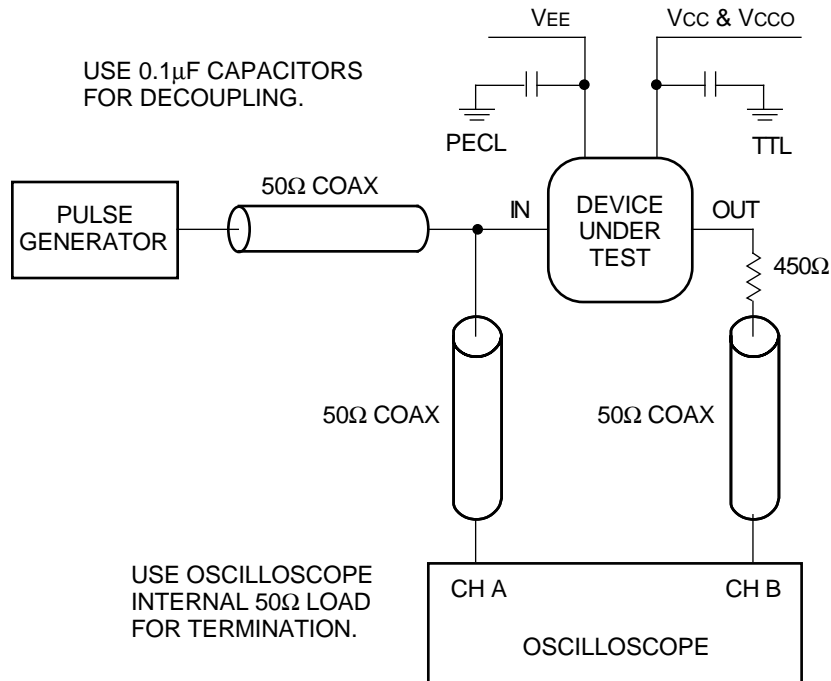

## ECL/TTL PROPAGATION DELAY — SINGLE ENDED

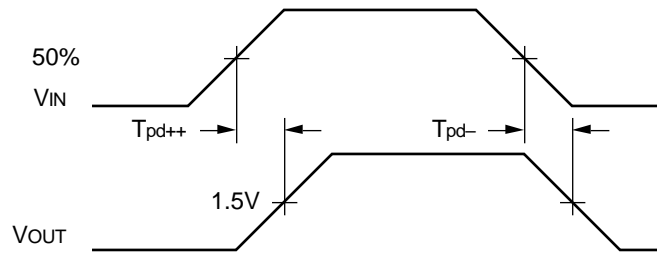

## ECL/TTL WAVEFORMS: RISE AND FALL TIMES

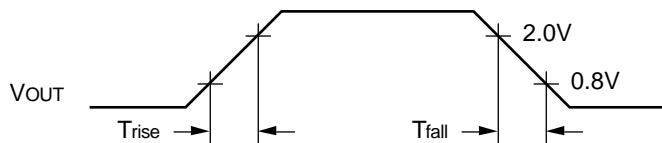

## PRODUCT ORDERING CODE

Ordering Code	Package Type	Operating Range
SY10H842ZC	Z16-1	Commercial
SY10H842ZCTR	Z16-1	Commercial
SY100H842ZC	Z16-1	Commercial
SY100H842ZCTR	Z16-1	Commercial